

# TRANSPALETA HIDRÁULICA

**SURTEK**  
HERRAMIENTAS PARA PROFESIONALES

CÓDIGO  
**TRHB15**

**DIAGRAMA DE  
DESPIECE**

## CARACTERÍSTICAS

CAPACIDAD	LEVANTE MÁXIMO	LEVANTE MÍNIMO	DISTANCIA TOTAL (BRAZO A BRAZO)	FECHA
1,5 t	190 mm	75 mm	365 mm	07/10/2021



No.	ID	ESPAÑOL	ENGLISH	No.	ID	ESPAÑOL	ENGLISH	No.	ID	ESPAÑOL	ENGLISH
1	TRHB15R1001	Varilla de liberación	Release Rod	9	TRHB15R1009	Rodillo de presión	Pressure Roller	17	TRHB15R1017	Perno elástico	Elastic Pin
2	TRHB15R1002	Cadena	Chain	10	TRHB15R1010	Buje	Bushing	18	TRHB15R1018	Palanca de control	Control Handle /
3	TRHB15R1003	Tornillo de ajuste	Adjusting Bolt	11	TRHB15R1011	Maneral	Draw-bar	19	TRHB15R1019	Rodillo	Roller
4	TRHB15R1004	Tuerca de ajuste	Adjusting Nut	12	TRHB15R1012	Obstructor de goma	Stop Rubber	20	TRHB15R1020	Perno elástico	Elastic Pin
5	TRHB15R1005	Eje con orificio	Axle with Hole	13	TRHB15R1013	Perno elástico	Elastic Pin	21	TRHB15R1021	Perno	Pin
6	TRHB15R1006	Perno elástico	Elastic Pin	14	TRHB15R1014	Resorte de cuchilla	Blade Spring	22	TRHB15R1022	Tablero de atracción	Pull Board
7	TRHB15R1007	Buje	Bushing	15	TRHB15R1015	Resorte	Spring	N/D producto No Disponible para venta \ N/D product Not Available for sale			
8	TRHB15R1008	Perno de rodillo	Roller Pin	16	TRHB15R1016	Perno elástico	Elastic Pin				

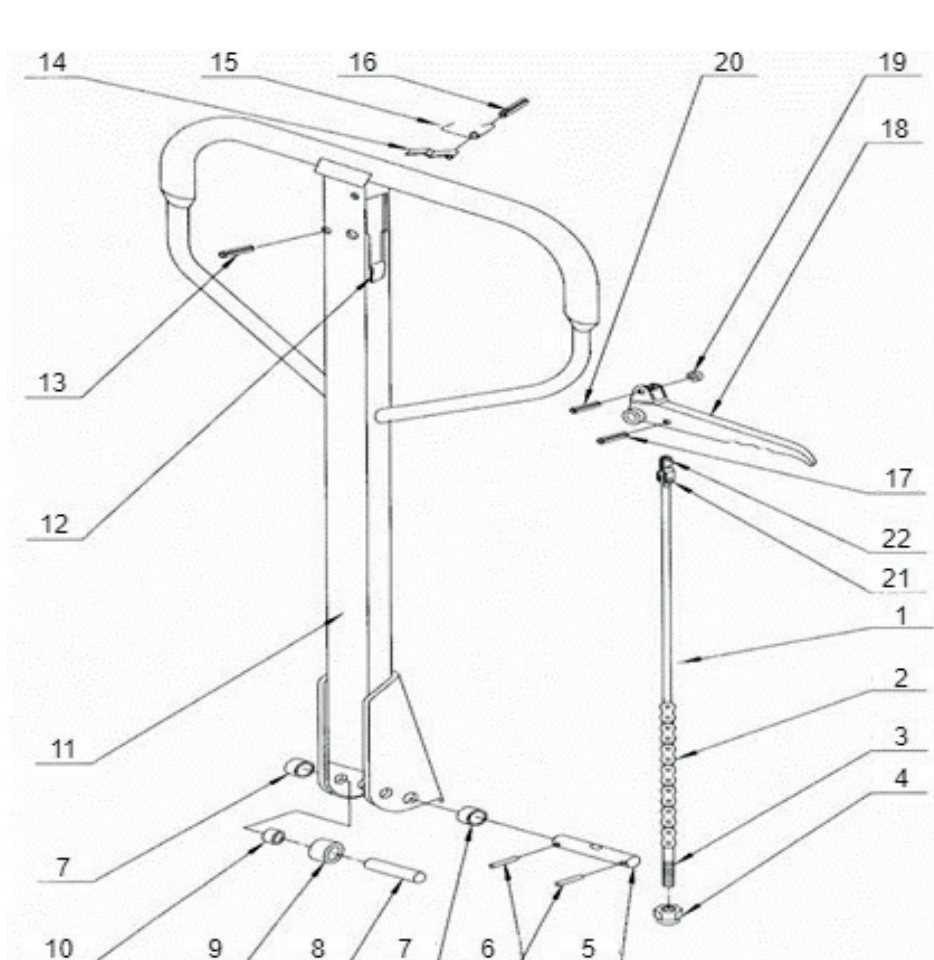



# TRANSPALETA HIDRÁULICA

CÓDIGO  
**TRHB15**

**DIAGRAMA DE  
DESPIECE**

## CARACTERÍSTICAS

CAPACIDAD	LEVANTE MÁXIMO	LEVANTE MÍNIMO	DISTANCIA TOTAL (BRAZO A BRAZO)	FECHA
1,5 t	190 mm	75 mm	365 mm	07/10/2021

No.	ID	ESPAÑOL	ENGLISH	No.	ID	ESPAÑOL	ENGLISH	No.	ID	ESPAÑOL	ENGLISH
50	TRHB15R1050	Tapa del Resorte	Spring Cap	63	TRHB15R1063	Anillo de retención	Retaining Ring	76	TRHB15R1076	Anillo de polvo	Dust Ring
51	TRHB15R1051	Resorte	Spring	64	TRHB15R1064	Baleros	Bearing	77	TRHB15R1077	Varilla de pistón	Piston Rod
52	TRHB15R1052	Pistón de la bomba	Pump Piston	65	TRHB15R1065	Eje para rueda de carga	Shaft of loading Wheel	78	TRHB15R1078	Balín	Steel Ball
53	TRHB15R1053	Anillo para polvo	Dust Ring	66	TRHB15R1066	Tuerca	Nut	79	TRHB15R1079	Tornillo de cierre	Screw Plug
54	TRHB15R1054	Empaque	Seal	67	TRHB15R1067	Tornillo	Screw	80	TRHB15R1080	O'Ring	O'Ring
55	TRHB15R1055	Cubierta de polvo	Dust Cover	68	TRHB15R1068	Placa de palanca	Lever Plate	81	TRHB15R1081	Tornillo	Bolt
56	TRHB15R1056	Anillo de bloqueo	Locking Ring	69	TRHB15R1069	Perno elástico	Elastic Pin	82	TRHB15R1082	Resorte	Spring
57	TRHB15R1057	Arandela	Washer	70	TRHB15R1070	Cartucho de válvula	Valve Cartridge	83	TRHB15R1083	Husillo de valvular de seguridad	Spindle of Safety Valve
58	TRHB15R1058	Baleros	Bearing	71	TRHB15R1071	Cuerpo de bomba	Pump Body	84	TRHB15R1084	Grasera	Grease Cup
59	TRHB15R1059	Rueda de carga	Loading Wheel	72	TRHB15R1072	Arandela de empaque	Seal Washer	85	TRHB15R1085	Cilindro	Cylinder
60	TRHB15R1060	Perno elástico	Elastic Pin	73	TRHB15R1073	Tornillo de cierre	Screw Plug	86	TRHB15R1086	Cubitera para baleros	Cover of Bearing
61	TRHB15R1061	Perno elástico	Elastic Pin	74	TRHB15R1074	Empaque	Seal				
62	TRHB15R1062	Placa de empuje	Thrust Plate	75	TRHB15R1075	O'Ring	O'Ring				

N/D producto No Disponible para venta \ N/D product Not Available for sale

